

# GLENEAGLES PLAT THREE REPLAT ONE

A REPLAT OF ALL OF TRACTS M, L-1 AND R-1 OF "GLENEAGLES PLAT THREE", ACCORDING TO THE PLAT THEREOF, AS RECORDED IN PLAT BOOK 51 AT PAGES 145 THROUGH 148 OF THE PUBLIC RECORDS OF PALM BEACH COUNTY, FLORIDA, IN SECTION 21, TOWNSHIP 46 SOUTH, RANGE 42 EAST, PALM BEACH COUNTY, FLORIDA

105

SHEET 4 OF 6

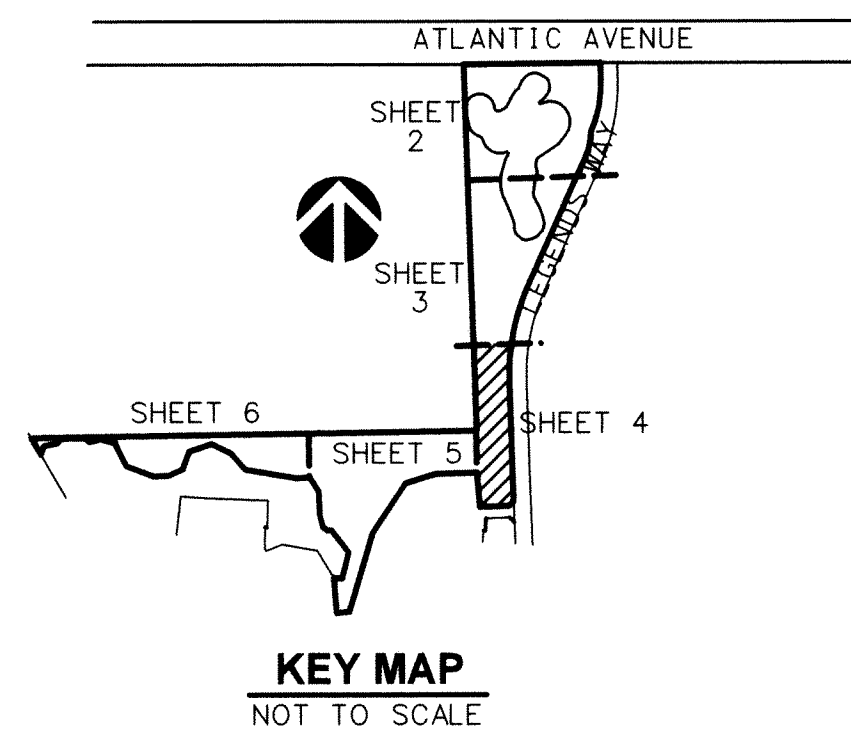
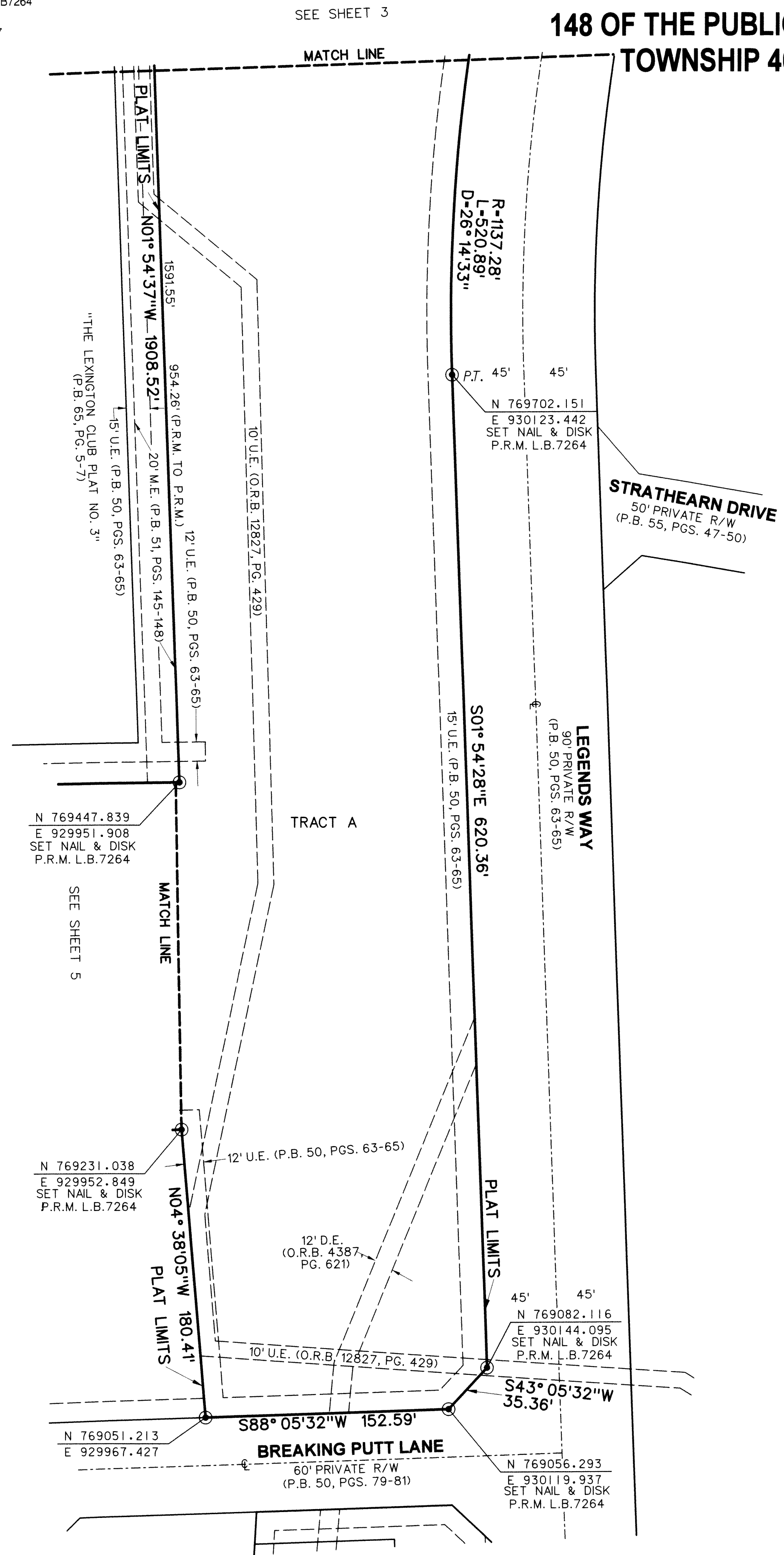
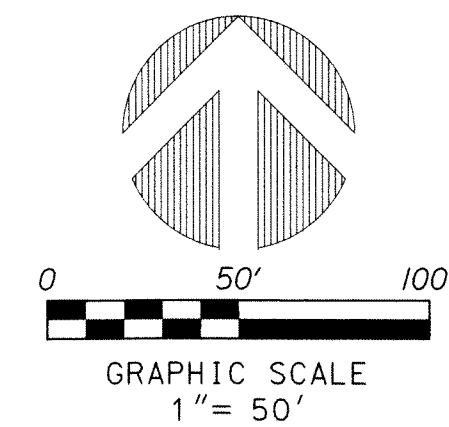

**LEGEND:**

- ⊙ SET P.R.M. (UNLESS OTHERWISE NOTED) - 4" x 4" CONC. MON. WITH ALUMINUM DISK STAMPED •LB7264 CENTERLINE
- ⊕ LEGENDS WAY 90' PRIVATE R/W (P.B. 50, PGS. 63-65)

**ABBREVIATIONS:**

- CONC. CONCRETE
- COR. CORNER
- D. DELTA (CENTRAL ANGLE)
- D.B. DEED BOOK
- D.E. DRAINAGE EASEMENT
- F.P.L. FLORIDA POWER AND LIGHT COMPANY
- L. ARCLength
- L.B. LICENSED BUSINESS
- L.B.E. LANDSCAPE BUFFER EASEMENT
- L.M.A.E. LAKE MAINTENANCE ACCESS EASEMENT
- L.M.E. LAKE MAINTENANCE EASEMENT
- L.S. LICENSED SURVEYOR
- L.S.E. LIFT STATION EASEMENT
- L.W.D.D. LAKE WORTH DRAINAGE DISTRICT
- M.E. MAINTENANCE EASEMENT
- PBC PALM BEACH COUNTY
- MON. MONUMENT
- O.R.B. OFFICIAL RECORDS BOOK
- P.B. PLAT BOOK
- P.B.C.R. PALM BEACH COUNTY RECORDS
- P.C. POINT OF CURVATURE
- P.C.C. POINT OF COMPOUND CURVATURE
- P.R.C. POINT OF REVERSE CURVATURE
- P.T. POINT OF TANGENCY
- PG. PAGE
- PGS. PAGES
- P.L.S. PROFESSIONAL LAND SURVEYOR
- P.O.B. POINT OF BEGINNING
- P.O.C. POINT OF COMMENCEMENT
- P.R.M. PERMANENT REFERENCE MONUMENT
- P.S.M. PROFESSIONAL SURVEYOR & MAPPER
- P.U.D. PLANNED UNIT DEVELOPMENT
- R. RADIUS
- R.P.B. ROAD PLAT BOOK
- R/W RIGHT-OF-WAY
- SEC. SECTION
- U.E. UTILITY EASEMENT
- SECTION 21-46-42- SECTION 21, TOWNSHIP 46 SOUTH RANGE 42 EAST
- F.D.O.T. FLORIDA DEPARTMENT OF TRANSPORTATION

**NOTES:**  
**COORDINATES, BEARINGS AND DISTANCES**

COORDINATES SHOWN ARE GRID  
DATUM - NAD 83 1990 ADJUSTMENT  
ZONE - FLORIDA EAST  
LINEAR UNIT - US SURVEY FOOT  
COORDINATE SYSTEM 1983 STATE PLANE  
TRANSVERSE MERCATOR PROJECTION  
ALL DISTANCES ARE GROUND, UNLESS OTHERWISE NOTED  
SCALE FACTOR = 1.0000271  
GROUND DISTANCE X SCALE FACTOR = GRID DISTANCE  
ALL BEARINGS AS SHOWN HEREON ARE GRID, BASED ON A GRID BEARING OF N01°54'37" WEST ALONG THE WEST LINE OF THE NORTHEAST ONE-QUARTER OF SECTION 21, TOWNSHIP 46 SOUTH, RANGE 42 EAST.